

# 225 SERIES

## Horizontal Hold Down Clamps | Product Overview

### Features:

- Low profile
- Stainless steel model furnished without plastic grip
- Available DESTACO® Toggle Lock Plus™

### Applications:

- Assembly
- Checking fixtures
- Closures
- Woodworking

### Also Available:

See page MC-ACC-1 for accessories

Accommodates M8 or 5/16" spindle accessory

Covered under one or more U.S./International Patents

### 225-U/USS Flanged Base U-Bar



-USS Stainless Steel Model

### 225-UR/URSS Flanged Base U-Bar DESTACO® Toggle Lock Plus



-URSS Stainless Steel Model

### 225-UB/UBSS ⓘ Straight Base U Bar



-UBSS Stainless Steel Model

## Technical Information

Model	Max. Holding Capacity	Clamp Bar Opening (+10°)	Handle Opening (+10°)	Weight	Accessories (Supplied)	
					Spindle Assembly	Flanged Washers
225-U	2220 N [500 lbf]	92°	70°	[0.55 lb] 0,25 kg	225208-M	507107
225-USS	2670 N [600 lbf]				207943-M	507907
225-UR	2220 N [500 lbf]			[0.69 lb] 0,31 kg	225208-M	507107
225-URSS	2670 N [600 lbf]				207943-M	507907
225-UB ⓘ	2220 N [500 lbf]			[0.55 lb] 0,25 kg	225208-M	507107
225-UBSS ⓘ	2670 N [600 lbf]				207943-M	507907

ⓘ This item is available upon request

# 225 SERIES

## Horizontal Hold Down Clamps | Holding Capacities

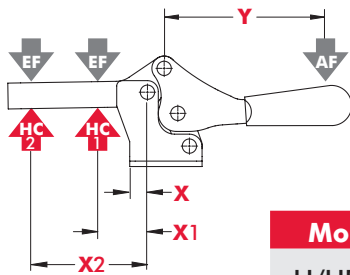

Model	X	X1	X2	Y	±HC1	±HC2	±EF(X1):AF	±EF(X2):AF
U/UR/UB	[0.12]	[1.25]	[2.50]	[3.56]	[500 lbf] 2220 N	[250 lbf] 1110 N	12:1	5:1
USS/URSS/ UBSS	3,0	31,8	63,5	90,4	[600 lbf] 2670 N	[300 lbf] 1340 N		

Dimensions shown "mm [inch]" ± HC = Holding Capacity, EF = Exerting Force, AF = Applied Force  
See page MC-TEC-4 for additional information.

### Dimensions | -U/-USS/-UB/-UBSS

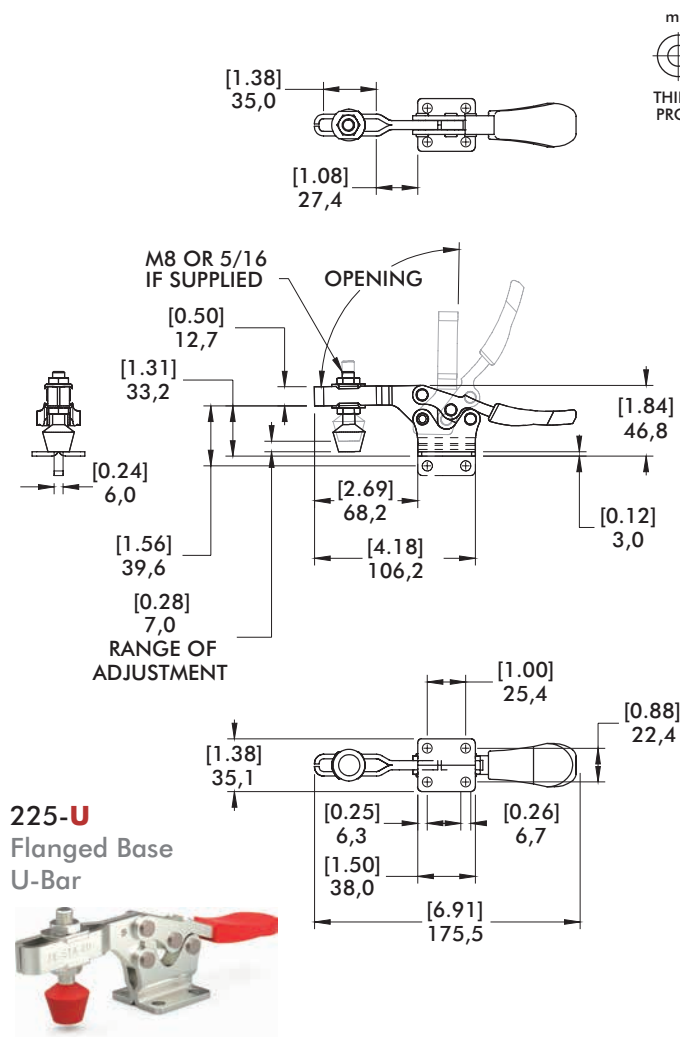

### Dimensions | -UR/-URSS

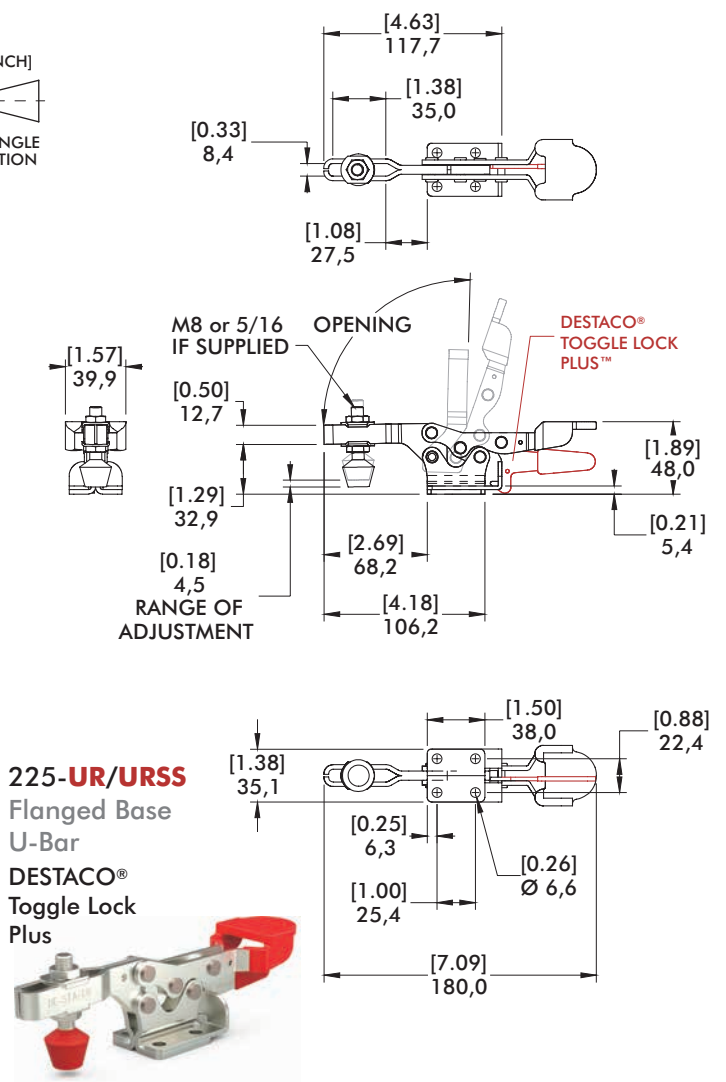

# 225 SERIES

## Horizontal Hold Down Clamps | Dimensions | -UF

### 225-UF

Front Mount Base

U-Bar

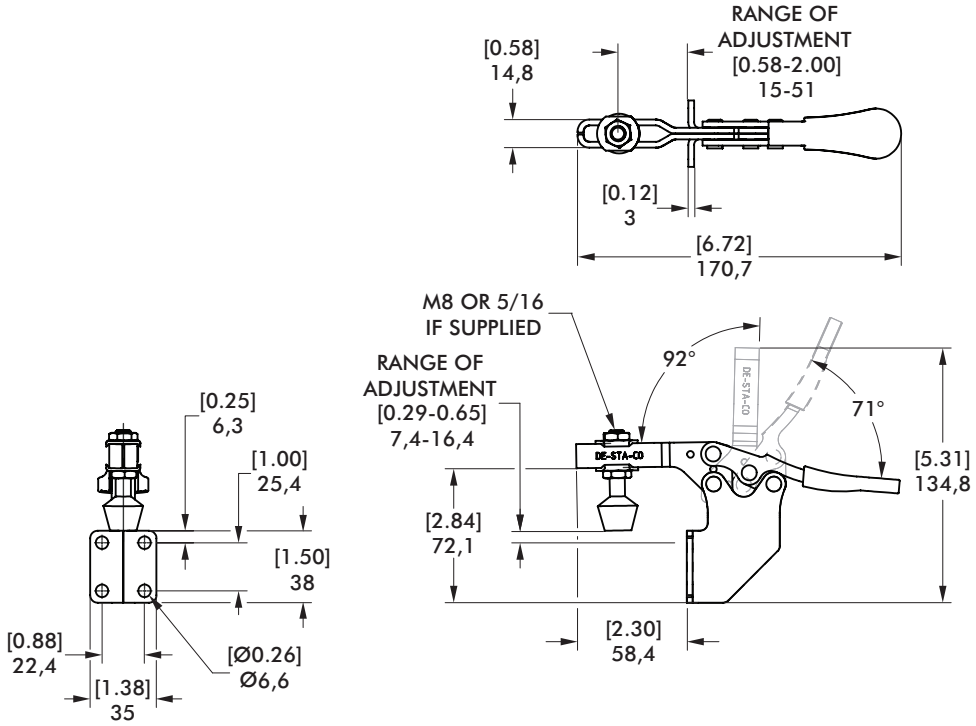
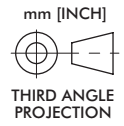

- 5 handle colors - see page MC-PRO-7 for details