

6000-SW SERIE

Manueller Schwenkspanner | Produktübersicht

Produktmerkmale:

- In rechts- oder linksschwenkbarer Ausführung erhältlich
- Spannarm um 90° schwenkbar
- Höhere Spannkraft als eine pneumatische Version
- Durchgangsmontage
- Griff für bessere Ergonomie um bis zu 180° radial verstellbar
- Spannarm ist 360° frei positionierbar

Anwendungen:

- Montieren
- Checking fixtures
- Schweißen
- Tensioning devices

6002-SWL

Linksschwenkender Spannarm



6002-SWR

Rechtsschwenkender Spannarm



6004-SWL

Linksschwenkender Spannarm



6004-SWR

Rechtsschwenkender Spannarm



Spanner in offener Position.

Technische Informationen, Abmessungen

Farbige Griffe

Erhältlich für Modelle dieser Serie. Am Ende der Modellnummer -Y, -G, -B, -K anfügen.



Modell	Schwenkrichtung	Max. Haltekraft*	Gesamthub [in] mm	Schwenkhub [in] mm	Spannhub [in] mm	Gewicht [lb] kg
6002-SWL	LH	[400 lbf] 1780 N	[0.75] 19.1	[0.53] 13.5	[0.22] 5.6	[0.95] 0.43
6002-SWR	RH	[400 lbf] 1780 N	[0.75] 19.1	[0.53] 13.5	[0.22] 5.6	[0.95] 0.43
6004-SWL	LH	[600 lbf] 2670 N	[1.50] 38	[0.87] 22	[0.63] 16	[1.32] 0,6
6004-SWR	RH	[600 lbf] 2670 N	[1.50] 38	[0.87] 22	[0.63] 16	[1.32] 0,6

*Gerader Schub. Berücksichtigt nicht den Klammerarm.



6000-SW SERIE

Manueller Schwenkspanner | Abmessungen

6002-SWL/SWR



6002-SWL

6002-SWR

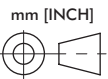
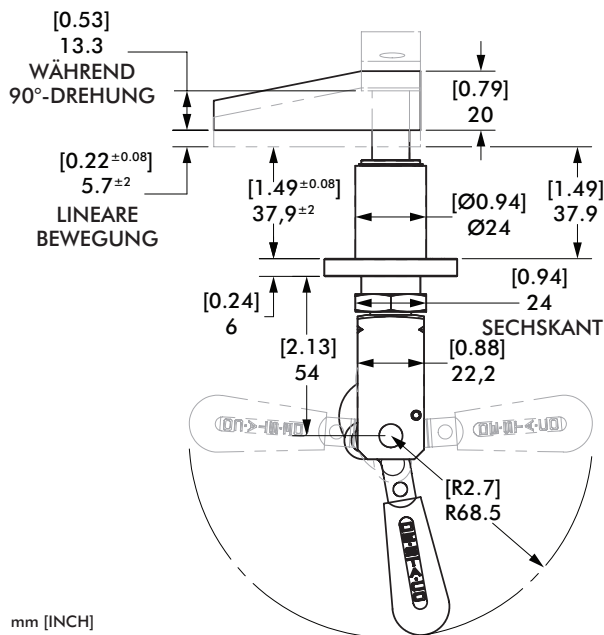
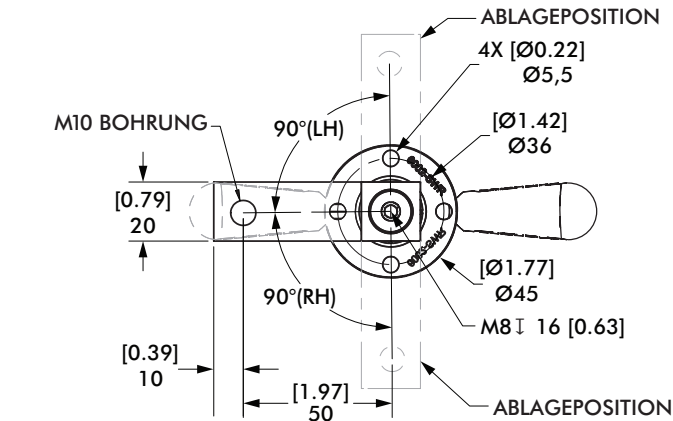

6004-SWL/SWR



6004-SWL

6004-SWR

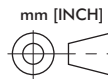
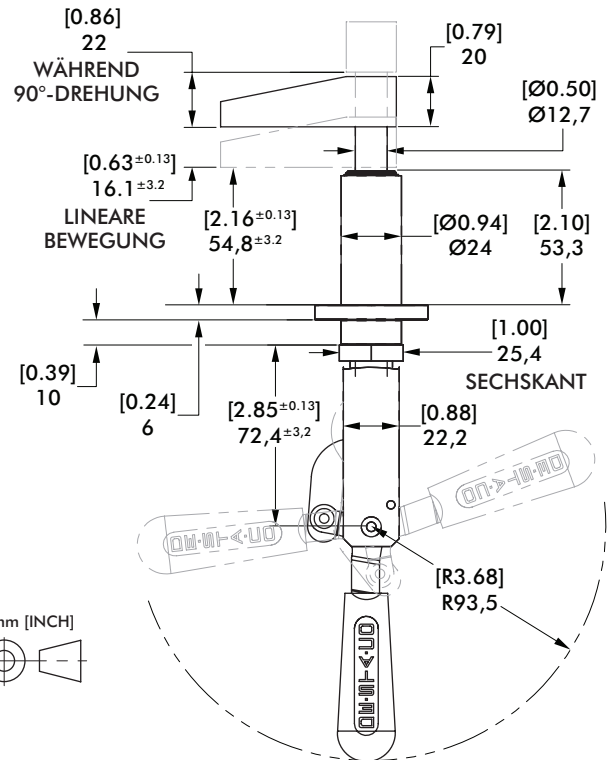
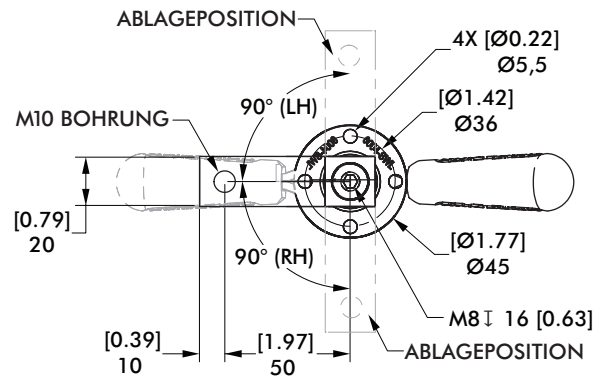

Eingeleitete Handkraft (am Griff) [lbs] N	[25]	[20]	[15]	[10]
Zugkraft (zentriert)	[360] 1601	[288] 1281	[216] 961	[144] 641
Spannkraft (mit Standardspannarm)	[229] 1019	[189] 841	[149] 663	[108] 480

Eingeleitete Handkraft (am Griff) [lbs] N	[40]	[30]	[20]	[10]
Zugkraft (zentriert)	[576] 2562	[432] 1922	[288] 1281	[144] 641
Spannkraft (mit Standardspannarm)	[323] 1437	[269] 1197	[189] 841	[108] 480

Höhere Spannkraft als pneumatische Version