

84A5-1 SERIES

Cam Type Sheet Metal Grippers | Ordering Information

84A5 - 11 D5 A AA PA

Fixed Lower Jaw Opening Options

Description

- 76° Jaw Opening (Standard)
- X 30° Jaw Opening
- Y 45° Jaw Opening
- Z 60° Jaw Opening

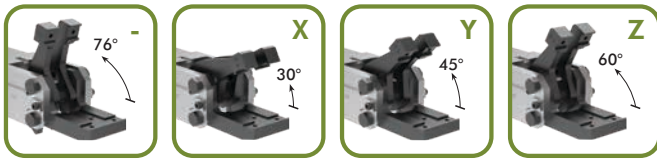

Jaw Arrangement Options

Description

- 11 Double Upper, Single Lower, Straight Design
- 13 Double Upper and Lower, Straight Design

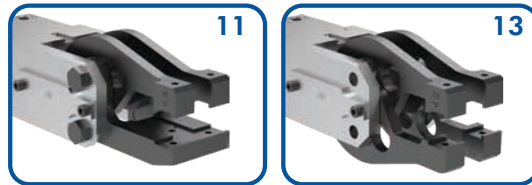

Moveable Lower Jaw Opening Options

Description

- 76° Jaw Opening (Symmetrical)
- X 30° Jaw Opening (Symmetrical)
- Y 45° Jaw Opening (Symmetrical)
- Z 60° Jaw Opening (Symmetrical)
- R 76° Upper/15° Lower Jaw
- S 30° Upper/15° Lower Jaw
- T 45° Upper/15° Lower Jaw
- U 60° Upper/15° Lower Jaw

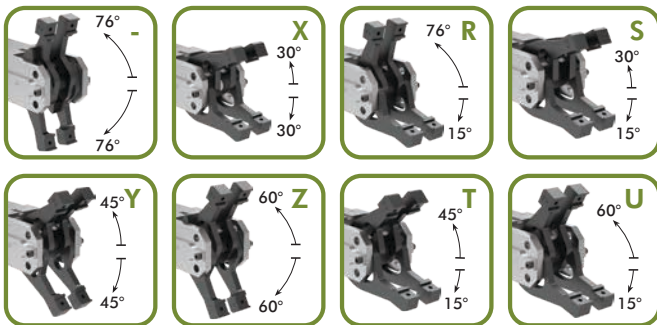

Specifications	Unit	
Piston	mm	50
Actuation Time (open/close)	sec	0.6
Air Consumption per Double Stroke at 5 bar	L	0.66

84A5-1 SERIES

Cam Type Sheet Metal Grippers | Ordering Information

Gripper Teeth and Points Options (Upper and Lower)

Steel Teeth

- 00 None
- AA 8JZ-014-3

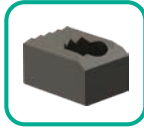

Plastic Teeth

- 00 None
- KA 8JZ-021-1*

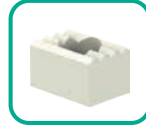

* Cannot be used with A8 sensor option.

Steel Points (Upper only)

- 00 None
- PA 8MJ-1001-1
- PB 8MJ-1002-1
- PC 8MJ-1003-1

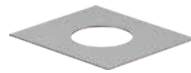

Shims for gripper teeth available
Order Separately **8SB-003-1**
Dimensions: 14,8 x 13 x 0,15 mm

Sensor Options

Description

- 00 None
- A8 Workpiece Control, Switching Distance 7mm
8EA-092-1 (for 84A5-11 only)*
- D5 Double Sheet Control, M12x1 Plug - 8EA-087-1
- GK 2X D5
- GN A8 + D5 (for 84A5-11 only)

*Cannot be used with KA plastic teeth option.

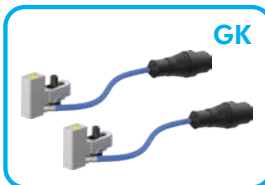
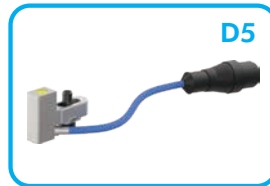

Shims for Sensor A8 available
Order Separately **8MB-003-1**

Mounting Options

Description

- 0 None
- A Rear Flange - 8MA-196-1



84A5.11 SERIES (SINGLE FIXED LOWER JAW)

Cam Type Sheet Metal Grippers | Dimensions and Ordering Information

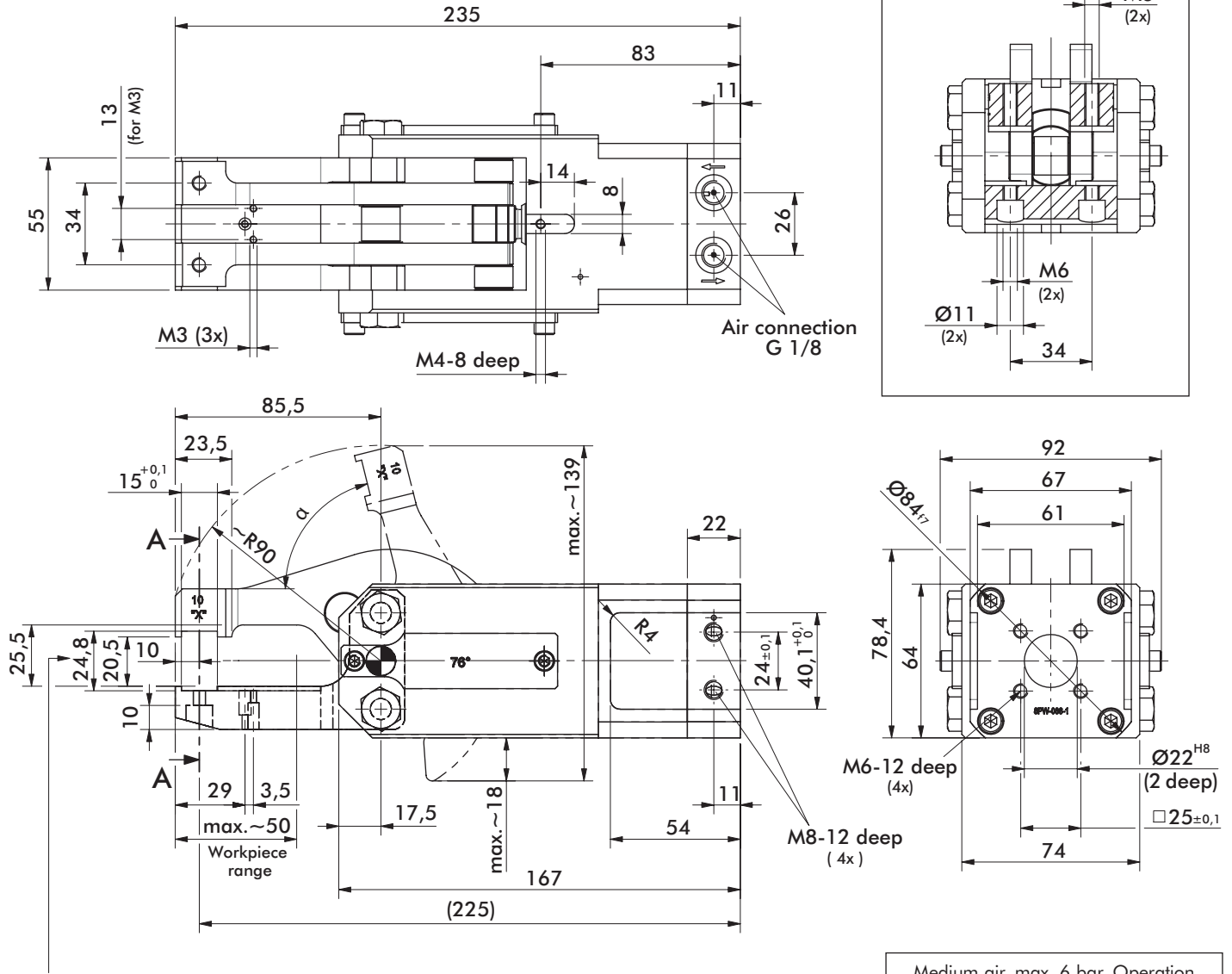
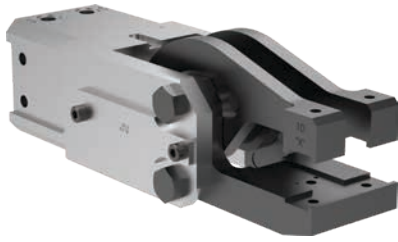

Addition of gripper teeth height and thickness of the clamped plate must be 24,8 mm. It might be necessary to use shim plates or to grind off the gripper teeth.

Medium air, max. 6 bar. Operation with oil-free air is permissible.

NOTE! Any extension of the moveable or fixed gripper jaws as well as the additional attachment of weights will void warranty.

Model 84A5.11	Opening Angle α	Clamping force at 5 bar $\sim N$ [lbf]	Weight Kg [lbs]
-	76°	2000 [450]	2,8 [6.17]
X	30°		
Y	45°		
Z	60°		

84A5.13 SERIES (DOUBLE SYMMETRICAL JAW)

Cam Type Sheet Metal Grippers | Dimensions and Ordering Information

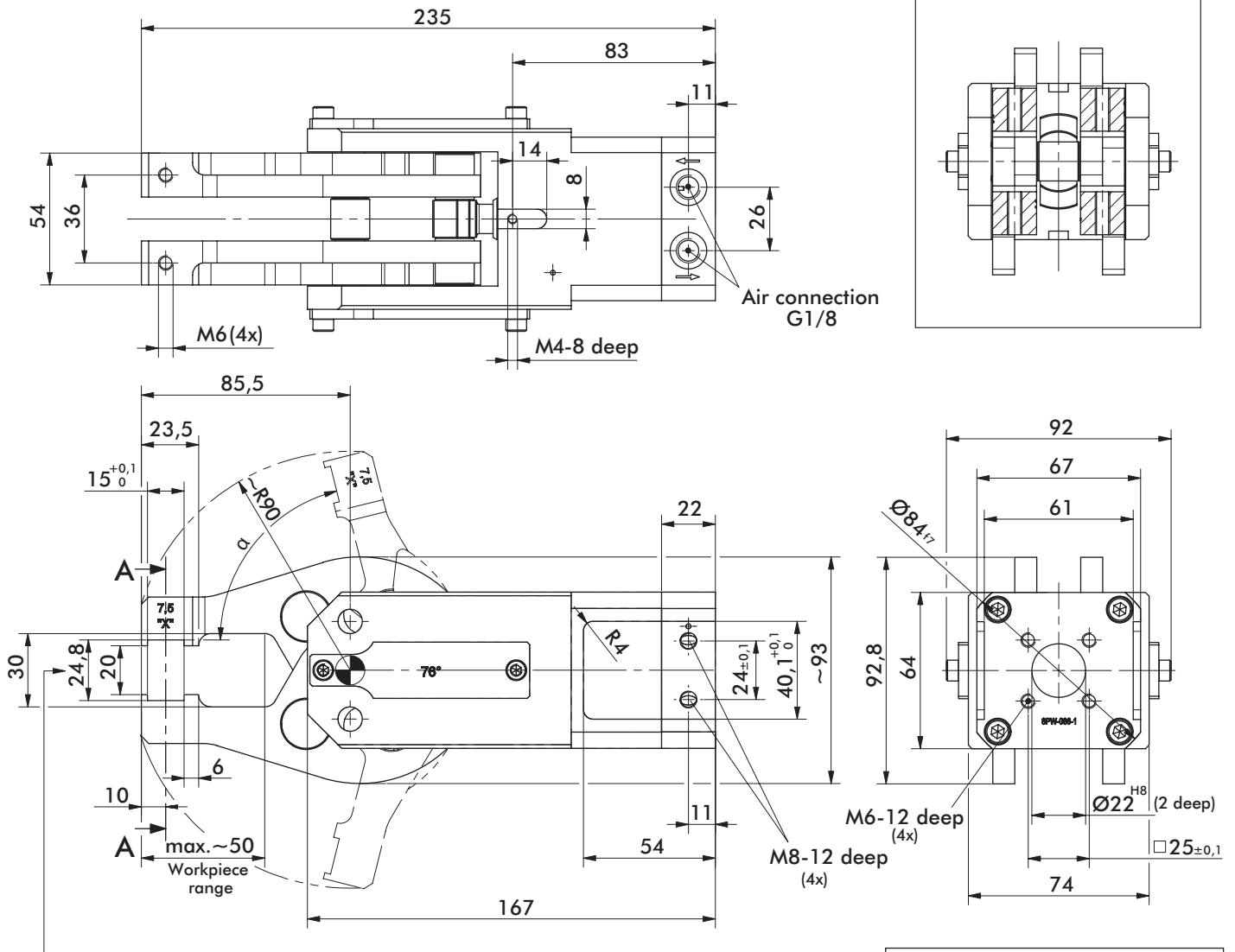

Addition of gripper teeth height and thickness of the clamped plate must be 24,8 mm. It might be necessary to use shim plates or to grind off the gripper teeth.

Medium air, max. 6 bar. Operation with oil-free air is permissible.

NOTE! Any extension of the moveable or fixed gripper jaws as well as the additional attachment of weights will void warranty.

Model 84A5.13	Opening Angle α Symmetrical	Clamping force at 5 bar ~N [lbf]	Weight Kg [lbs]
-	76°	1200 [270]	2,8 [6.17]
X	30°		
Y	45°		
Z	60°		

84A5.13 SERIES (DOUBLE 15° LOWER JAW)

Cam Type Sheet Metal Grippers | Dimensions and Ordering Information

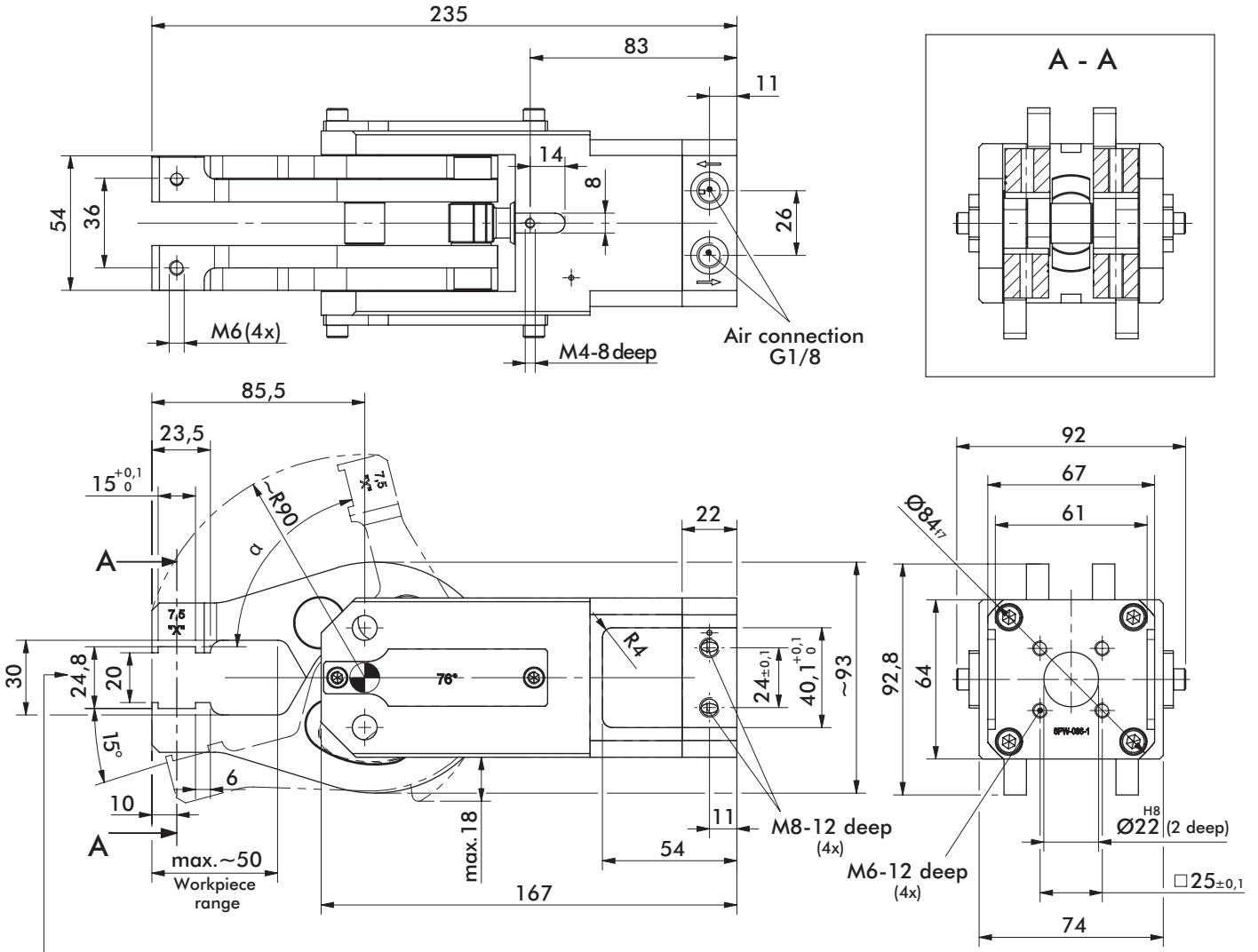
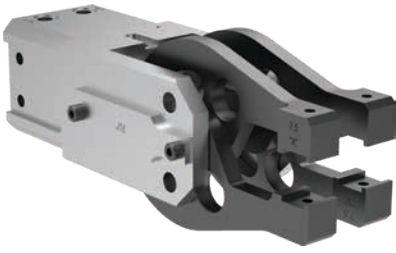

Addition of gripper teeth height and thickness of the clamped plate must be 24,8 mm. It might be necessary to use shim plates or to grind off the gripper teeth.

Medium air, max. 6 bar. Operation with oil-free air is permissible.

NOTE! Any extension of the moveable or fixed gripper jaws as well as the additional attachment of weights will void warranty.

Model 84A5.13	Opening Angle α Upper/Lower	Clamping force at 5 bar ~N [lbf]	Weight Kg [lbs]
R	76°/15°	1200 [270]	2,8 [6.17]
S	30°/15°		
T	45°/15°		
U	60°/15°		

84A5-1 SERIES ACCESSORIES

Cam Type Sheet Metal Grippers | Dimensions and Ordering Information

Mount

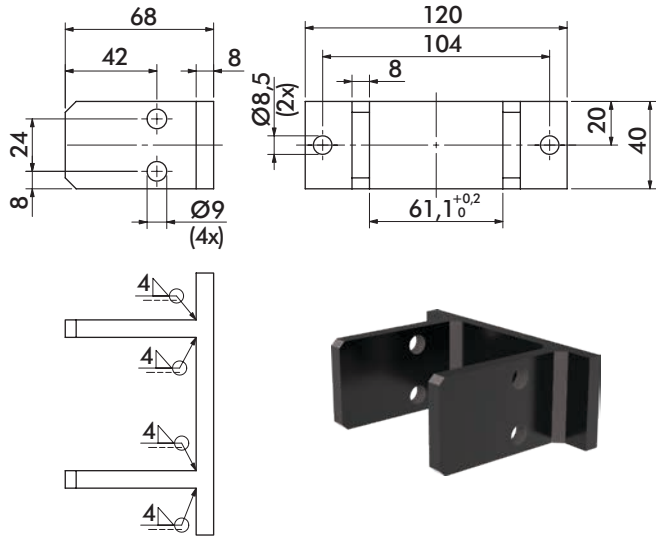

Steel Teeth

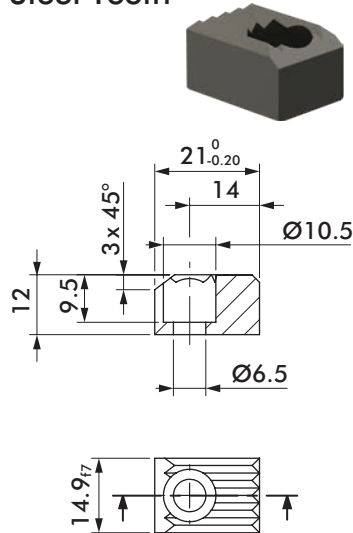

Plastic Teeth

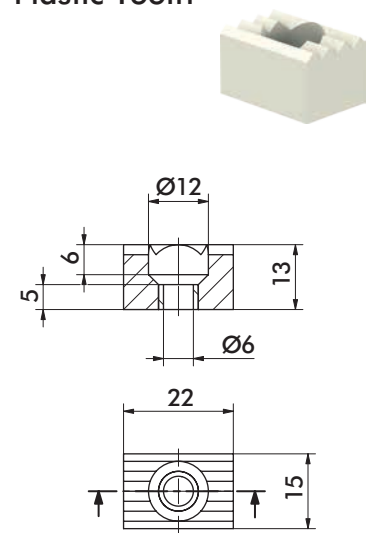

Mount

Rear Flange

Part

8MA-196-1

Steel Teeth

Serrated

Part

8JZ-014-3

Plastic Teeth

Serrated

Part

8JZ-021-1

Steel Points

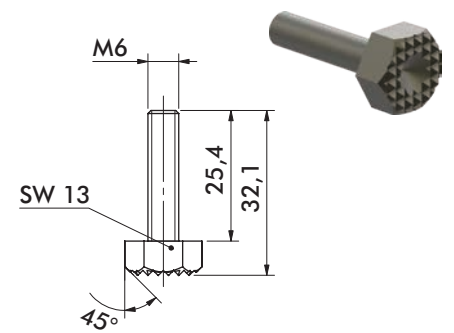
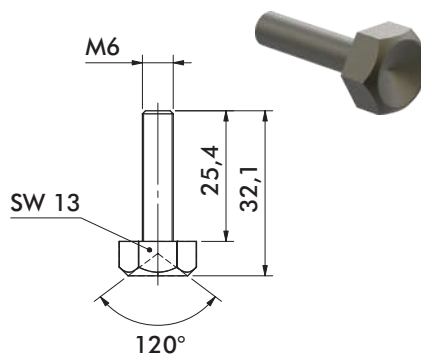
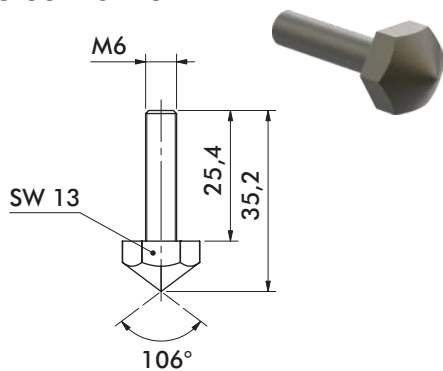

Steel Point

Pointed

Part

8MJ-1001-1

Steel Point

Flat

Part

8MJ-1002-1

Steel Point

Serrated

Part

8MJ-1003-1

Sensors

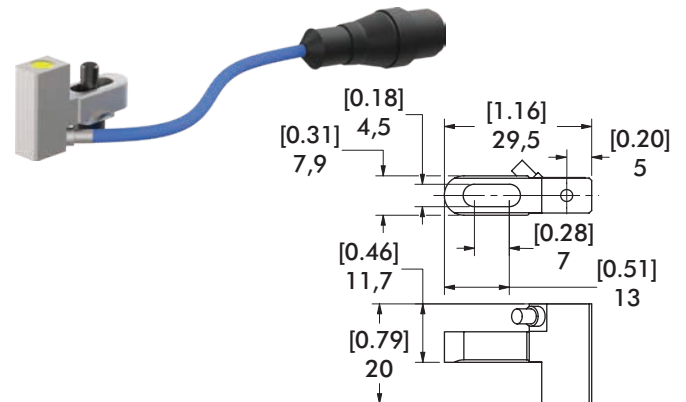
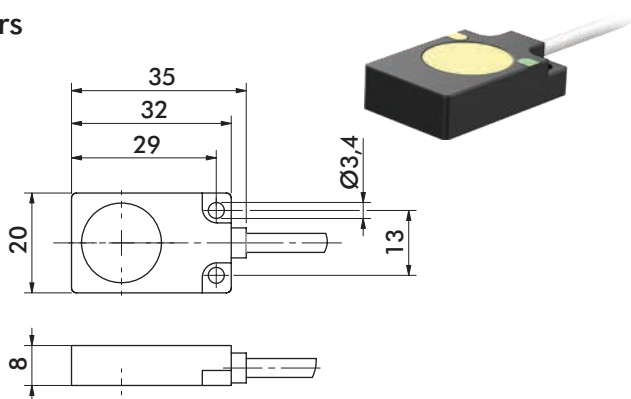

Workpiece Control Sensor

7mm Sensing Distance, 2m Cable

Part

8EA-092-1

Double Sheet Control Sensor

1.5mm Sensing Distance

Part

8EA-087-1